

RECEPTION GLASS



RECEPTIONGLASS

Accogliere e coordinare. Linee arrotondate, sinuose, elementi lineari, dettagli di grande valenza tecnologica e accostamenti di ricchi materiali suggeriscono una ricerca e un progetto di design che parte dalla persona per risolvere la necessità dell'azienda e dello spazio.

To receive and to organise. Rounded, winding shapes, straight lines are details of great importance while the combination of rich materials suggest the study of a design which takes into consideration the person to solve the needs of the working space.

RECEPTIONGLASS

Programmi reception integrabili in vetro e melaminico.

Modular reception programs in melamine and glass.



bianco/vetro
white/glass



rovere/vetro
oak/glass



wengé/vetro
wengé/glass



ciliegio/vetro
cherry/glass



Il successo di un sistema d'arredo è determinato dalla sua possibilità compositiva. Elementi curvi e rettilinei si integrano tra loro favorendo lo sviluppo di nuove soluzioni formali. L'inserimento di modanature in alluminio disegna varianti grafiche nuove ed eleganti, personalizzando il fronte pubblico.

The success of a furnishing line is due to the versatility of its components. Curved and straight elements combine together creating always new solutions. The addition of aluminium details give an elegant and personalized touch to the reception composition.

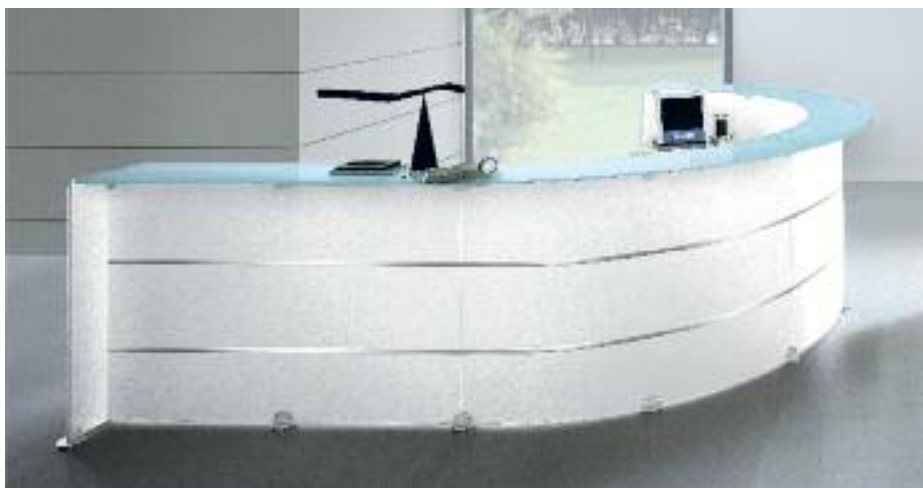

RECEPTIONGLASS

RECEPTIONGLASS

La desk-reception si trasforma in centro di smistamento di relazioni e incontri di lavoro. Felice convivenza di contenuti tecnici ed estetici, di moderna progettualità e tradizione artigianale.

The reception desk becomes a sorting and a meeting place. Happy combination of technical and esthetical aspects, of modern design and traditional handicraft.







All'esterno una sinuosa curva per accogliere l'ospite, caratterizzata dagli inserti in alluminio che ne amplificano il gioco estetico, all'interno un grande e organizzato piano di lavoro; unione tra l'azienda e il mondo esterno.

Outside a winding curve to welcome the guest, characterized by the inserts in aluminum finish, inside a big and organized working top, a linking unit between your company and the outside world.

RECEPTIONGLASS

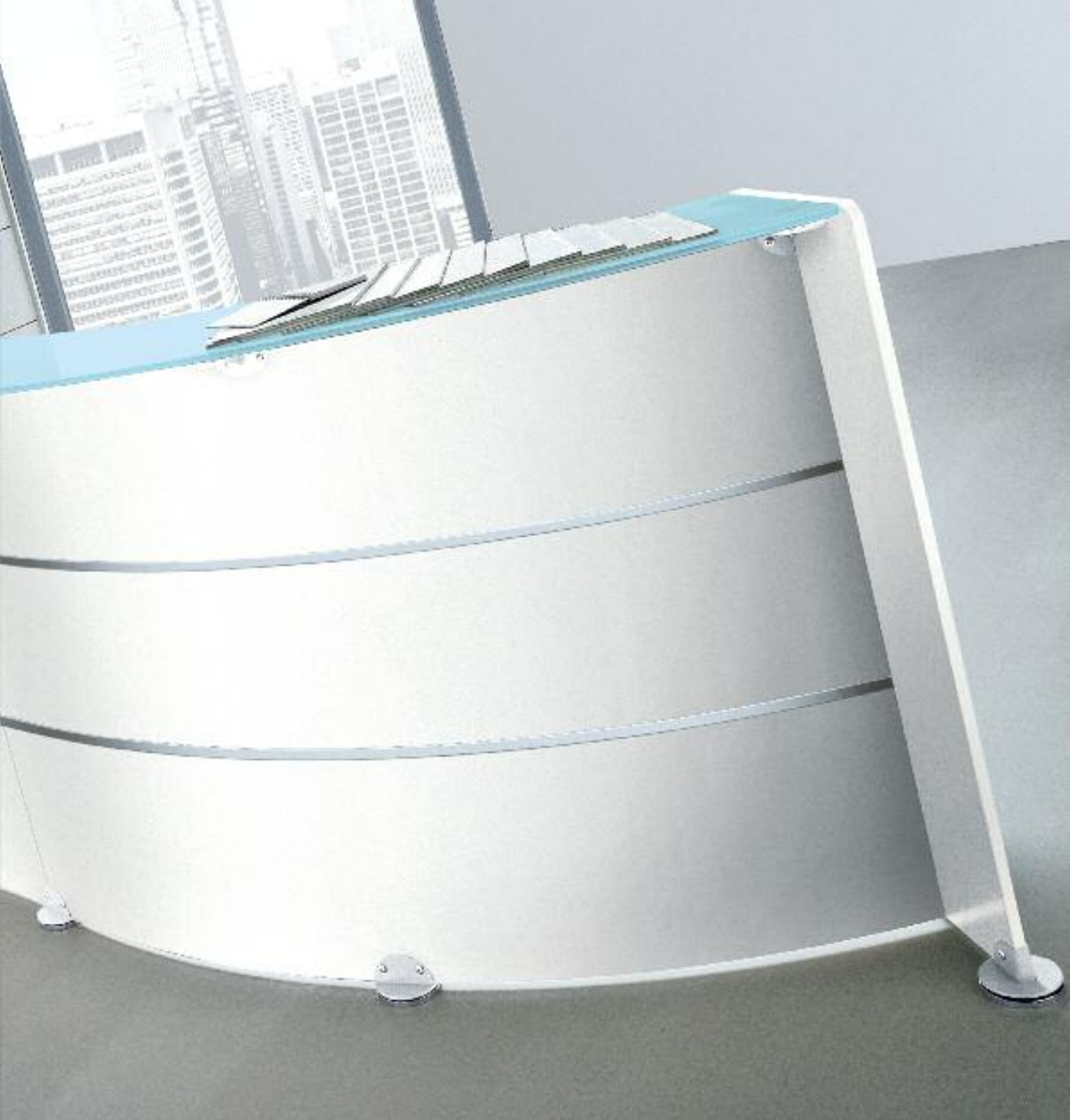





Reception circolare con piano di lavoro e mensola di cortesia avvolgente. La raffinatezza delle finiture e l'eleganza delle forme sono le espressioni di un sistema d'arredo completo, versatile, evoluto.

The refinement of the finishes and the elegance of the shapes are the expressions of a complete, versatile and evolved finishing line.





RECEPTIONGLASS

I piani sagomati si sposano con le pannellature curve, garantendo una corretta privacy per lavorare assumendo la doppia valenza di arredo deputato all'accoglienza e isola di lavoro operativa autosufficiente.

Shaped working tops match with curved counters granting privacy to work on your own but at the same time to welcome the guests as well.







La flessibilità della pannellatura frontale offre infinite possibilità di interpretazione estetiche e funzionali; il maniglione di appoggio in alluminio ne è un esempio per dare la giusta connotazione d'arredo personalizzato.

The flexible character of the counters give a wide range of possibilities to furnish in a functional way and in accordance with your taste. The aluminum counter beam is just an example on how to give a personal touch to the reception unit.









RECEPTIONGLASS

Una scelta prestigiosa per rivelare la propria identità
A glamorous choice to reveal your own identity.















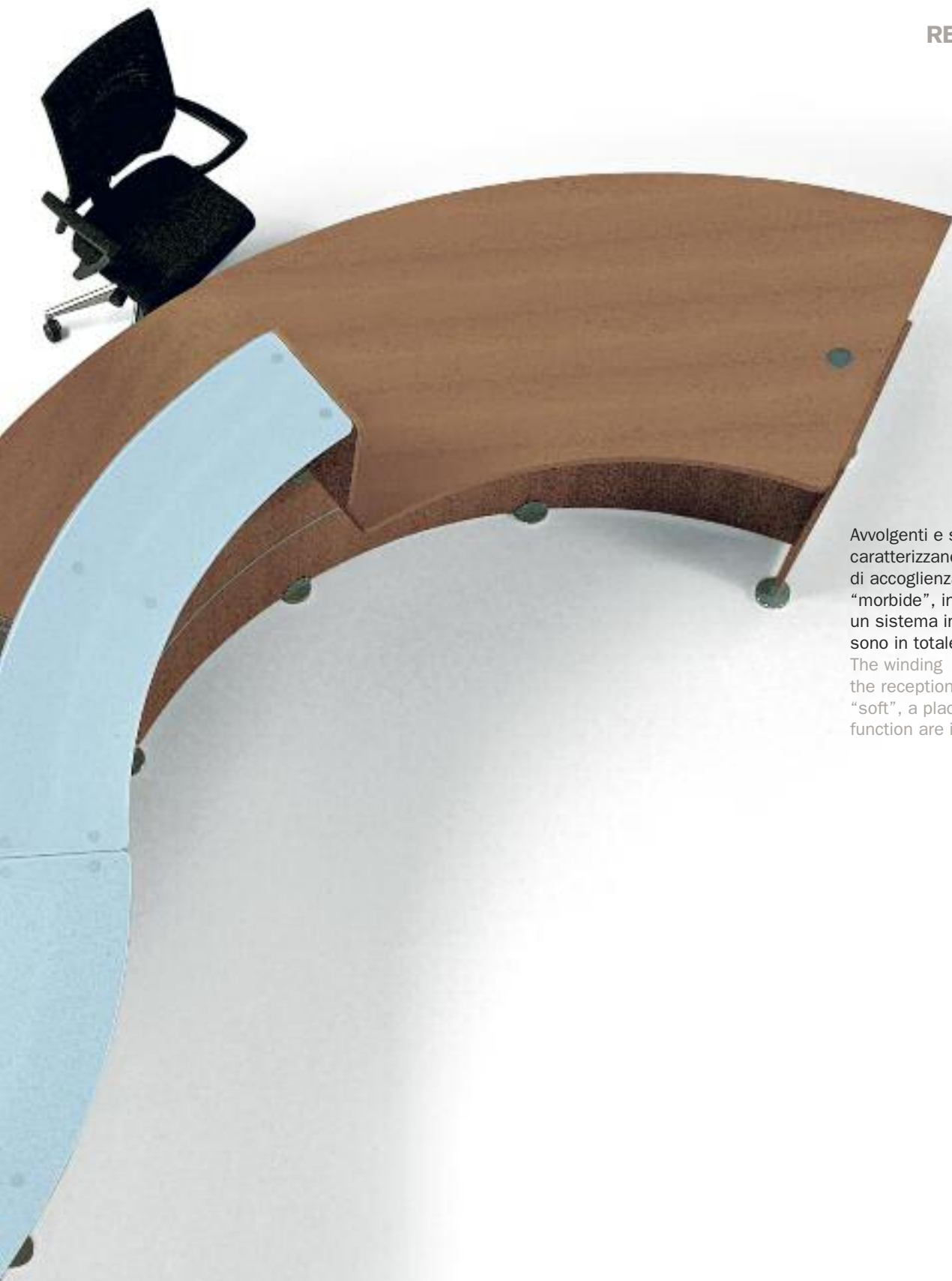

Avvolgenti e sinuose le curve caratterizzano e definiscono le aree di accoglienza rendendole “morbide”, integrando facilmente un sistema in cui forma e funzione sono in totale armonia.

The winding curves characterize the reception areas making them “soft”, a place where shape and function are in total harmony.





L'alluminio, materiale eccellente e ricco, si esalta nel contrasto luminoso tra pannellature con l'inserimento dei dettagli ideati per trasformare e caratterizzare l'avvolgente reception.

The aluminium details and the counters play together giving a personal and unique touch to the reception.

RECEPTIONGLASS



Ospitalità ed eleganza sono caratteristiche peculiari in un sistema creato per rispondere al meglio alle esigenze di rappresentanza di una moderna azienda. Dimensioni e linee si adattano a tutte le situazioni del ricevere.

Hospitality and elegance are the main aspects of this line which meets your needs while receiving people.





RECEPTIONGLASS

Da curve morbide e sinuose le linee e le forme si trasformano in essenziali, rigorose, pulite e lineari, per inserire la reception in ogni spazio e rispondere al gusto e allo stile delle esigenze.

Curved, winding lines turn into essential, minimal, strict lines helping you to fit the reception unit in every space, answering your needs and corresponding also to your taste and style.





- 1 - REBV060 Bancone curvo a 60° piano in cristallo
- 2 - REBV090 Bancone curvo a 90° piano in cristallo
- 3 - REBV100 Bancone diritto da 100 cm piano in cristallo
- 4 - REFC001 Coppia fianchi di chiusura
- 5 - REST151 Piano scrivania "interno" per curvo a 60°
- 6 - REST211 Piano scrivania "esterno" per curvo a 60°
- 7 - REST201 Piano scrivania "esterno" per curvo a 90°
- 8 - REST091 Piano scrivania "interno" per curvo a 90°
- 9 - REST101 Piano scrivania per bancone da 100cm
- 10 - REGA001 Gambone di sostegno per piani scrivania
- 11 - RESU001 Kit supporto + piedino per continuità
- 12 - RESU003 Coppia staffe di sostegno per piani scrivania

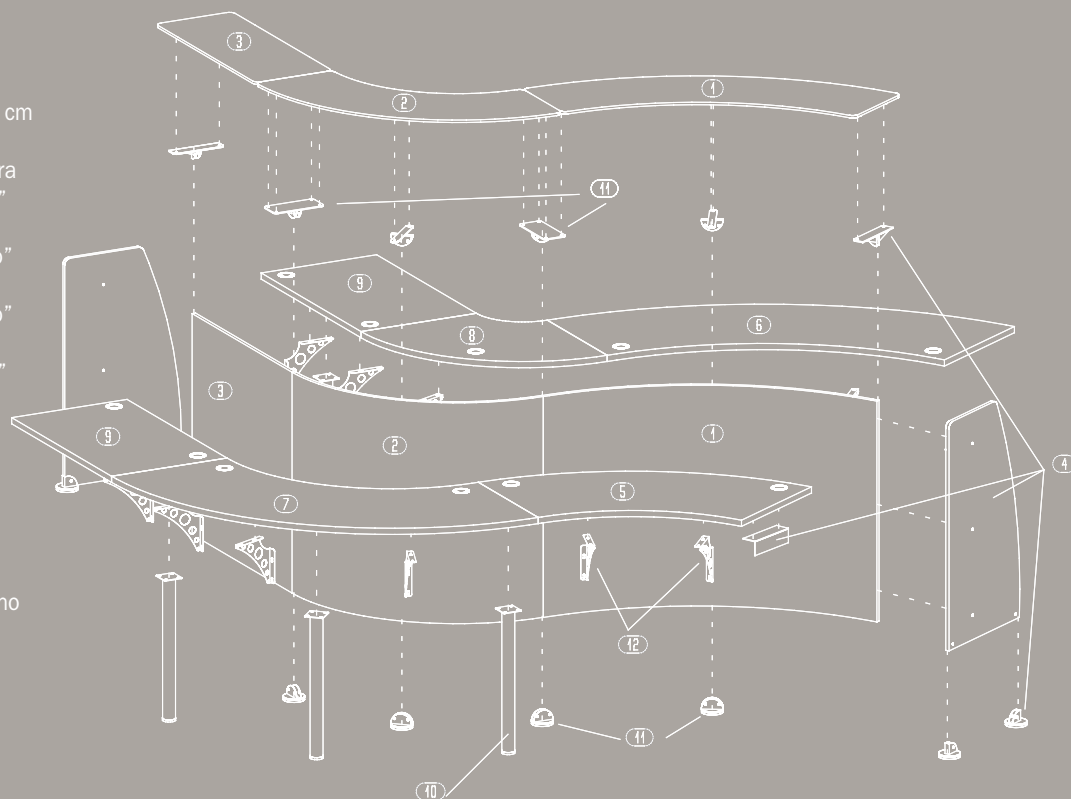

- 1 - REBM092 Bancone curvo a 90°basso interno
- 2 - REBM102 Bancone diritto da 100cm basso
- 3 - REBM090 Bancone curvo da 90° alto con piano in melaminico
- 4 - REBM100 Bancone diritto da 100cm alto con piano in melaminico
- 5 - REST201 Piano scrivania "esterno" per curvo a 90°
- 6 - REST101 Piano scrivania per modulo diritto da 100cm
- 7 - REFC016 Fianco di chiusura singolo basso sinistro
- 8 - RESU020 Kit supporto + piedino per continuità tra moduli bassi
- 9 - REFC014 Fianchetto di continuità per raccordo tra moduli alti e bassi
- 10 - REGA001 Gambone di sostegno per piani scrivania
- 11 - RESU001 Kit supporto + piedino per continuità
- 12 - RESU003 Coppia staffe di sostegno per piani scrivania
- 13 - REFC012 Fianco di chiusura singolo alto destro

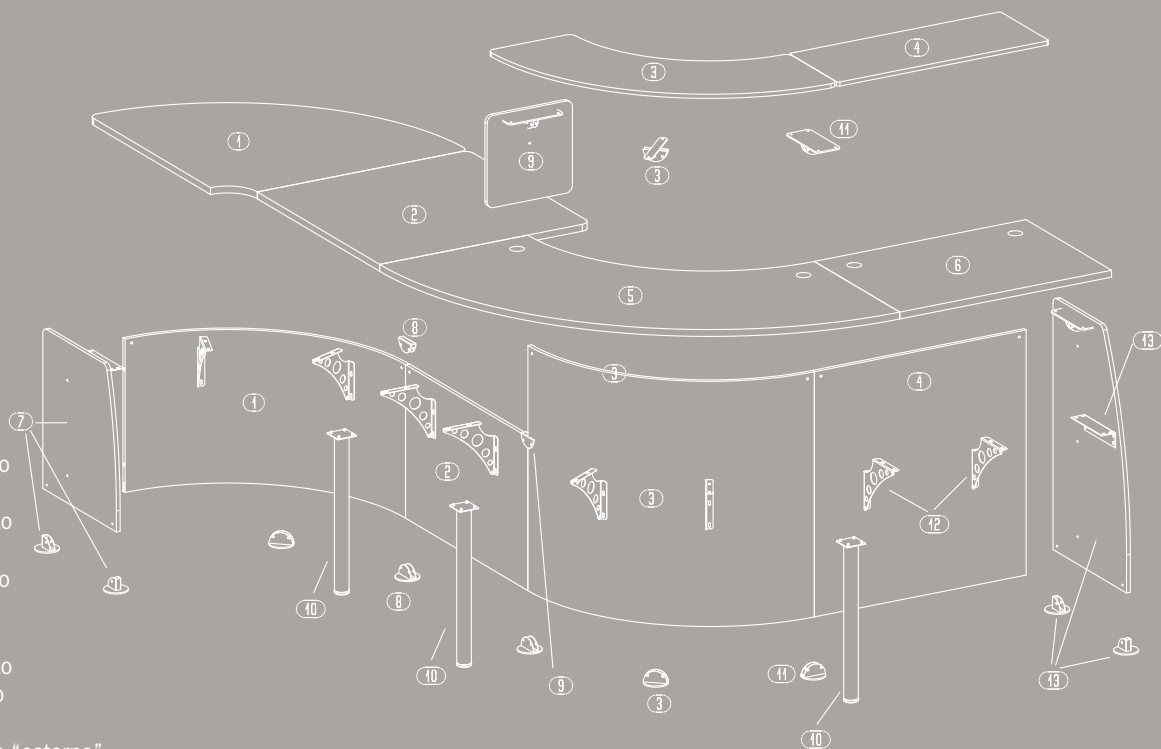

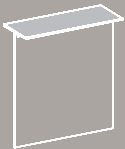

REBV100
100x40x112

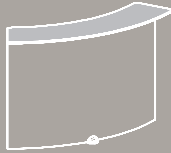

REBV060
173x57x112



REBV090
146x58x112

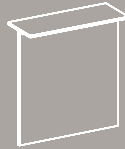

REBM100
100x40x112

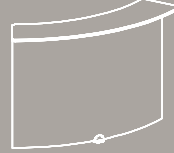

REBM060
173x57x112



REBM090
146x58x112

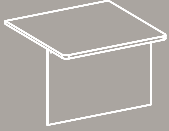

REBM102
100x100x72,5



REBM063
184x111x72,5



REBM062
226x115x72,5



REBM093
158x104x72,5

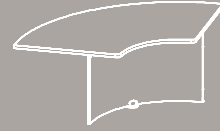

REBM092
221x117x72,5



REST101
100x70



REST211
226x91



REST151
154x81



REST201
221x95



REST091
119x74



RESU003

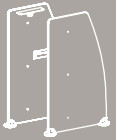

REFC001
67x112x12



REFC012
67x112x12



REFC013
67x112x12



REFC015
67x73x12



REFC016
67x73x12

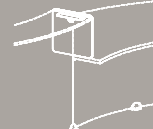

REFC014
40x40x2

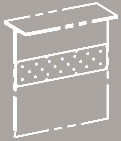

RESU006
100x25

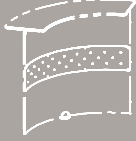

RESU005
132x25

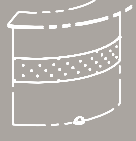

RESU015
135x25

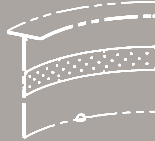

RESU004
161x25

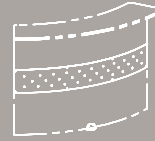

RESU014
163x25



REMA005



REMA004

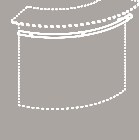

REMA003

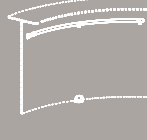

REMA002



REMA001



RESU009



RESU008



RESU007

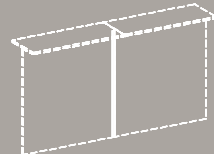

RESU010

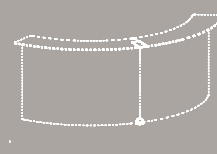

RESU001

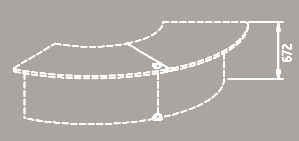

RESU020



REC0001
311x133x112



REC0002
357x181x112



REC0003
355x133x112



REC0004
331x235x112



REC0005
441x161x112



REC0006
452x154x112

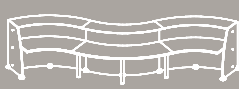

REC0007
495x133x112



REC0008
382x365x112



REC0009
418x211x112



REC0010
312x142x72/112



REC0011
350x185x72/112



REC0012
357x117x72/112



REC0013
434x161x72/112

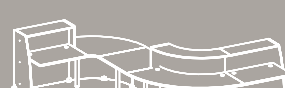

REC0014
370x370x72/112

FINISHINGS & COLOURS

Plani melaminico
Melamine tops

Moduli
Modules

Top
Tops Reception

Finiture
Finishes

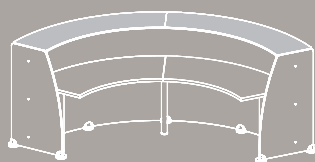
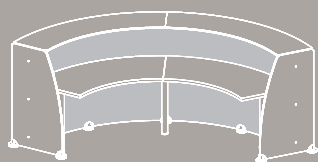
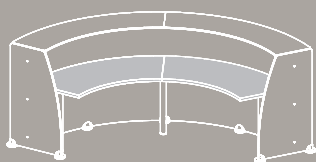

RR - rovere
WE - wengé
CA - ciliegio
BA - bianco
VE - cristallo

RR - oak
WE - wengé
CA - cherry
BA - white
VE - glass



RR



RR



RR



WE



WE



WE



CA



CA



CA

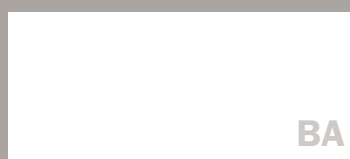

BA

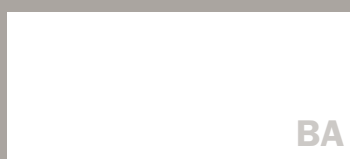

BA

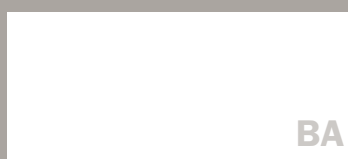

BA

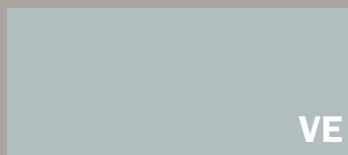

VE

Product details, aesthetics, finishes
or other data may be subject to
change without notice.
Particolari tecnici, estetici, finiture
o altro possono essere modificati
senza preavviso.

RECEPTIONGLASS

Art direction e
progetto grafico:
pubblicom@eurosito.com

Coordinamento:
MKT Quadrifoglio

Stampa: Grafiche Tintoretto srl
Giugno 2013 - Edizione 1

Codice LIOCARG

RECEPTION GLASS

